

# VOLKTEK

## IPI-442P-90-I

### Industrial Gigabit 90W PoE Injector

#### Description

IPI-442P-90-I (90W) is a single port PoE injector to deliver data and power to powered devices (PDs) via Cat-5e or Cat-6 Ethernet cables. The IPI-442P-90-I allows data transmission at multiple rate 10/100/1000Mbps and power delivery up to 90 Watts, respectively; it's suitable for the revolutionary PoE-based lighting system that creates a new breed of smart buildings where everything is connected to a vast Internet of Things (IoT).

The IPI-442P-90-I is a fan-less and could be deployed in the ceiling or outdoor cabinets for smart lighting or other network communication devices. Engineered with hardened components and enclosed in a rugged IP30 case, the IPI-442P-90-I can operate in wide temperatures from  $-40^{\circ}\text{C}$  to  $75^{\circ}\text{C}$  and have excellent tolerance capability to high vibration and shock suitable for high-power building automation applications.



**RoHS** **CE** **FC** **UL** **US LISTED**

#### Features Highlight

##### Simplified Installation w/ Compact Size

The IPI-442P-90-I injector provides a varied choice of deployment locations such as small spaces and harsh environment conditions. The MDI/MDI-X feature allow all devices to interact after plugged. When compatible devices are connected the injector will automatically detect and provide enough power for the device to operate.

##### Easy plug and play operation

The IPI-442P-90-I injector is the easy-to-setup and ready-to-use solution for the high PoE application system. Featuring Auto-MDI/MDIX and Auto-negotiation on the copper port, the injectors automatically detects and configures the best mode of operation over a link. This eliminates the need for user setup or configuration procedure and simplifies installation, once installed these injectors operate automatically.

##### Robust Switch Performance

With IP30 metal case, surge and ESD protection, the IPI-442P-90-I provides a high level of immunity against electromagnetic interference and heavy electrical surges which are easy to deploy in industrial environments. Furthermore, the IPI-442P-90-I offers 90W injector architecture to meet the requirements of high-power PDs, Fast Ethernet or Gigabit Ethernet in tough operating temperatures.

#### Applications

The PoE++ Injectors provide power of up to 90W to utilize power more efficiently on PDs such as PTZ IP Cam, VOIP Phones, WiFi AP and smart PoE lights.

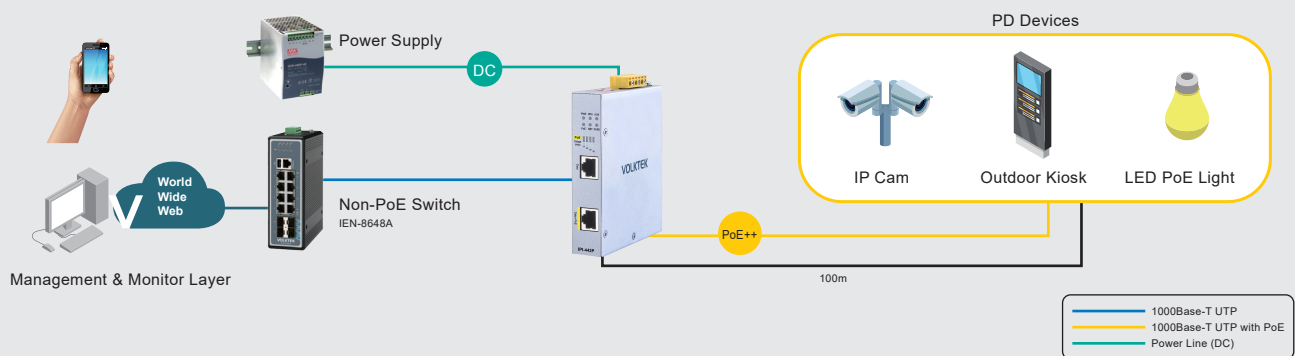

## Specifications

Standards	
IEEE 802.3af	PoE
IEEE 802.3at	PoE+
IEEE 802.3bt	4PPoE, 4-pair PoE
Interface	
Ports	1 x Gigabit for Data 1 x RJ45 for Data & PSE
DIP Switch	PWR, RPS, NBT, RSV
LED Panel	IPI-442P-90-I: PWR, RPS, ALM, PoE, NBT, 93~96W PoE Usage (15, 30, 60, 90)
Power	
Power Input	Dual 24~57V DC, Terminal Block
Power Consumption	IPI-442P-90-I: 9 Watt (System Only)
PoE Mode	IEEE 802.3af (PoE) IEEE 802.3at (PoE+) IEEE 802.3bt (4PPoE) IEEE 802.3bt (Type 4)
PoE Type	MidSpan
PoE Budget	90W: IPI-442P-90-I
Alarm Relay	One relay output with current carrying capacity of 1A@ 24V DC

Mechanical and Environment	
Housing	Aluminum, IP30
Dimensions (W x H x D)	25 x 116 x 100 mm (0.98 x 4.57 x 3.93 in)
Weight	220 g (0.49 lb)
Mounting	DIN Rail
Operating Temperature	-40~75°C (-40°F~167°F)
Storage Temperature	-40~85°C (-40°F~185°F)
Operating Humidity	5~95% RH (non-condensing)
Storage Humidity	5~95% RH (non-condensing)
Cooling Fan	Fan-less
Standards and Certifications	
EMI	FCC Part 15 Subpart B Class A
	EN 55011 class A
	EN 55032 class A
	CISPR 32 Class A
EMS	EN 61000-6-4
	EN 55024
	IEC/EN 61000-4-2 (ESD)
	IEC/EN 61000-4-3 (RS)
	IEC/EN 61000-4-4 (EFT)
	IEC/EN 61000-4-5 (Surge)
Safety	IEC/EN 61000-4-6 (CS)
	IEC/EN 61000-4-8
Safety	UL 61010-1 / UL 61010-2-210
Green Product	RoHS
Ordering Information	
IPI-442P-90-I	Industrial Gigabit 90W PoE Injector

Note:

\*The highest degree of temperature operation certified by UL is -40~70°C (-40°F~158°F).

\*Specifications subject to change without notice.

## Dimension

