

IEN-9425-RW

Unmanaged 5 x 10/100/1000 RJ45 & 2 x GbE SFP
Industrial Switch, Railway Approval

Description

IEN-9425-RW is a 5-port 10/100/1000 RJ45 downlink, and 2-port GbE SFP uplink unmanaged industrial-grade switch designed to meet the thermal requirements and environmental conditions of railway applications. The downlink ports connect to industrial devices and controllers. The fiber ports allow noise-free Gigabit Ethernet transmission for fast recovery, reliable and long-distance to other switches or the control center.

To keep a stable transmission of data the device uses rate limitation and QoS (Quality of Service) and prioritizes industrial applications using protocols like EIP, PROFINET, and GOOSE.

This switch is built with industrial-grade components, enclosed in an IP30 aluminum case with high thermal conductivity to protect the device from tools and hazards. Certified for use in railway applications, the device implements standard and safe communication and withstands vibration, shock, free fall, and temperatures ranging from -40°C ~ 75°C (-40°F ~ 167°F).



RoHS
CE FC



Features Highlight

Robust Switch Performance

IEN-9425-RW is enclosed within IP30 aluminum case and can able to sustain harsh temperature ranging between -40°C ~ 75°C . Along with this, the switch is built with various protection features such as ESD Protection, Surge Protection and Reverse Polarity Protection to deliver non-stop PoE service to the Powered Devices.



Advanced QoS Support

Understanding the need of smoother data transmissions for specific surveillance applications, the IEN-9425-RW supports IEEE 802.1p Quality of Service (QoS) which enhances bandwidth utilization to ensure time sensitive data gets delivered efficiently to mission-critical applications without any delay even during burst of high traffic. Addition to the beneficial fetures, the switch is also configured with efficient Storm Control functionalities which can only allow the traffic of a predefined rate. Both the QoS and Storm Control function can easily managed by DIP Switch without any burden of manual enable and disable.

Eco-friendly Green Ethernet Design

To address the concerns of increasing power consumption, IEN-9425-RW implements IEEE 802.3az Energy Efficient Ethernet (EEE) compliant Green Ethernet technology. This eco-friendly design allows the switch to automatically adjust power consumption and conserve energy during the periods of low data activity. This helps you to lower the energy usage significantly and help you save operational costs.

Applications

IEN-9648-RW/9425-RW series switches are designed to meet the demands of railway applications, including rolling stock and wayside installations. The switches guarantee reliable operation in industrial environments where vibration and shock are common place. Gigabit backbone, redundant ring increase the reliability of the communications and reduce cabling and wiring costs. These are compliant with mandatory sections of EN 50155, covering operating temperature, power input voltage, surge, ESD, and vibration, as well as conformal coating and power insulation, making the switches suitable for a variety of Railway applications.

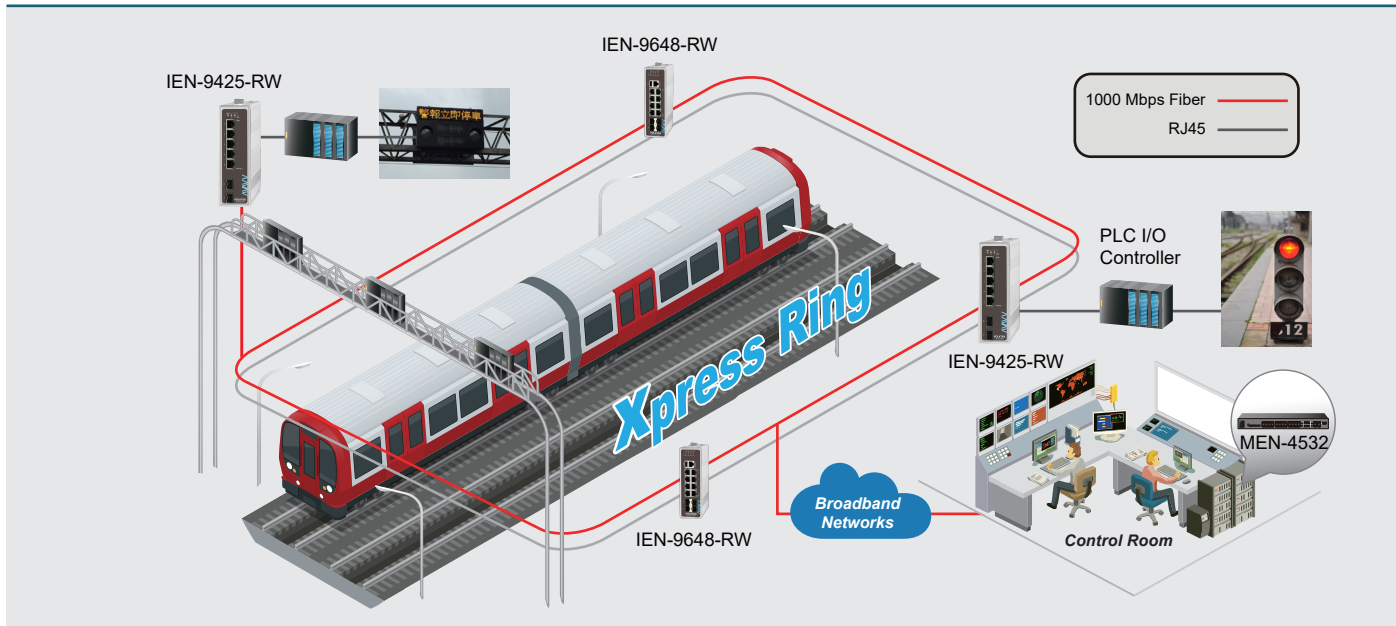
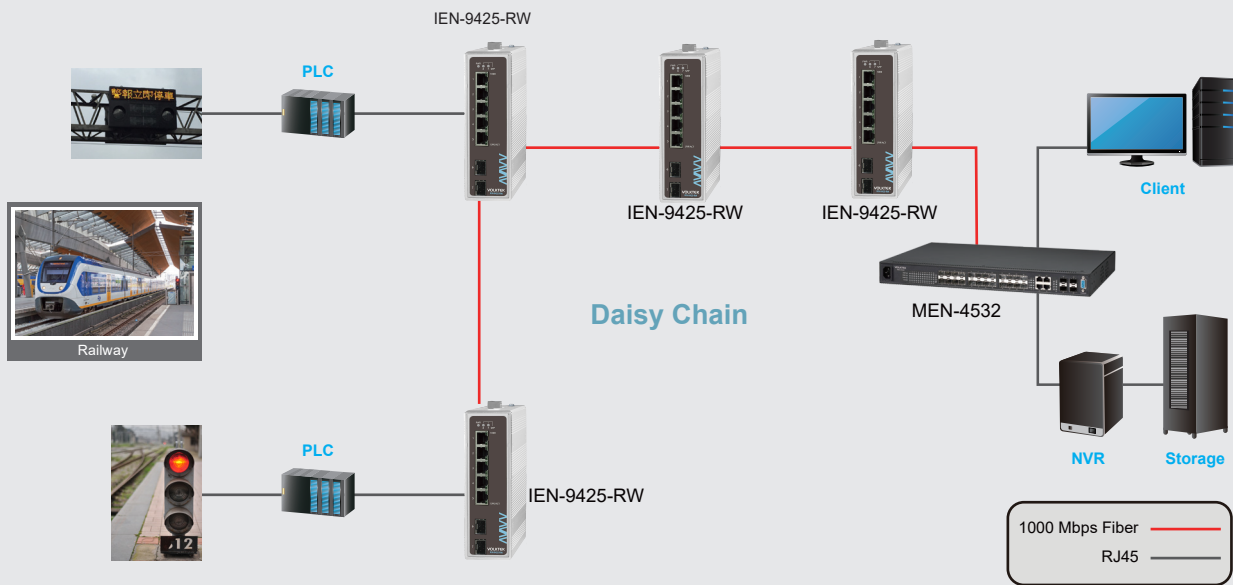

Specifications

Standards	
IEEE 802.3	10BASE-T
IEEE 802.3u	100BASE-TX
IEEE 802.3ab	1000BASE-T
IEEE 802.3z	1000BASE-SX/LX
IEEE 802.3	Nway Auto-negotiation
IEEE 802.3x	Flow Control
IEEE 802.1p	Class of Service
Interface	
Ports	5 x 10/100/1000BASE-T (RJ45) 2 x GbE SFP Slots
DIP Switch	Power voltage drop alarm setting (PWR & RPS)
LED Panel	PWR, SFP, 1000, LNK/ACT
Features	
Performance	Max Jumbo Frame Size: 10KBytes MAC Table Entries: 8K Switch Fabric: 14Gbps L2 Forwarding Rate: 10.4Mpps
Power	
Input Voltage	20~60VDC
Connection	Terminal Block, Mini-DIN
Power Consumption	System: 13W
Alarm Relay	One relay output with current carrying capacity of 1 A @ 24V DC
Mechanical and Environment	
Housing	Aluminum Case (IP30 protection)
Mounting	DIN-Rail, Rack-mount
Operating Temperature	-40°C~75°C (-40°F~167°F)
Storage Temperature	-40°C~85°C (-40°F~185°F)
Operating Humidity	5 to 95% RH (non-condensing)
Storage Humidity	5 to 95% RH (non-condensing)
Weight	869 g (1.9 lb)
Dimension (WxHxD)	50 x 161.5 x 119.9 mm (1.97 x 6.36 x 4.72 in)

Certifications		
CE	EMI	FCC Part 15 Subpart B Class A EN 55022: class A EN 55011: 2009 class A EN 61000-6-4
	EMS	EN 55024 EN 61000-6-2 EN 61000-4-2 (ESD) EN 61000-4-3 (RS) EN 61000-4-4 (Burst) EN 61000-4-5 (Surge) EN 61000-4-6 (CS) EN 61000-4-8 (PFMF)
Shock		IEC 60068-2-27
Freefall		IEC 60068-2-32
Vibration		IEC 60068-2-6
Rail Traffic		EN 50155 EN 50121-4 EN 61373
Ordering Information		
IEN-9425-RW	Unmanaged 5 x 10/100/1000 RJ45 & 2 x GbE SFP Industrial Switch, Railway Approval	
Optional Accessories		
Power Supply	SDR-120-48: DIN-Rail, 120W, 48VDC, Industrial Power Supply with PFC Function	
DIN-Rail Holder	DR-160 (for GST-160)	
GBM-104	1000BASE-SX 1.25G, Multi-mode SFP, 500m	
GBM-104-2	1000BASE-SX 1.25G, Multi-mode, 3.3V, 1310nm, 2Km	
GBM-104-10	1000BASE-LX 1.25G, Single mode SFP, 10Km	
GBM-123	1000BASE-LX Bi-di Single Mode SFP Module, 10Km	

*Specifications subject to change without notice.

*Industrial SFP with wide operating temperature from -40°C~85°C (-40°F~185°F) is available upon request

Dimension

